



## Ellison®/Sizzix® Multi-Purpose Work Station



### Parts included:

Item:	Qty:
(1) Top Assembly	1
(2) Left Leg Assembly	1
(3) Right leg Assembly	1
(4) Rear Support Brace	2
(5) Nameplate	2
(6) Middle Sliding Shelf	2
(7) Castor Wheel	4
(8) Long Screw for Leg Assembly	8
(9) Short Screw for Rear Support and Nameplate	10
(10) Allen Wrench	1
(11) Top Sliding Shelf	1

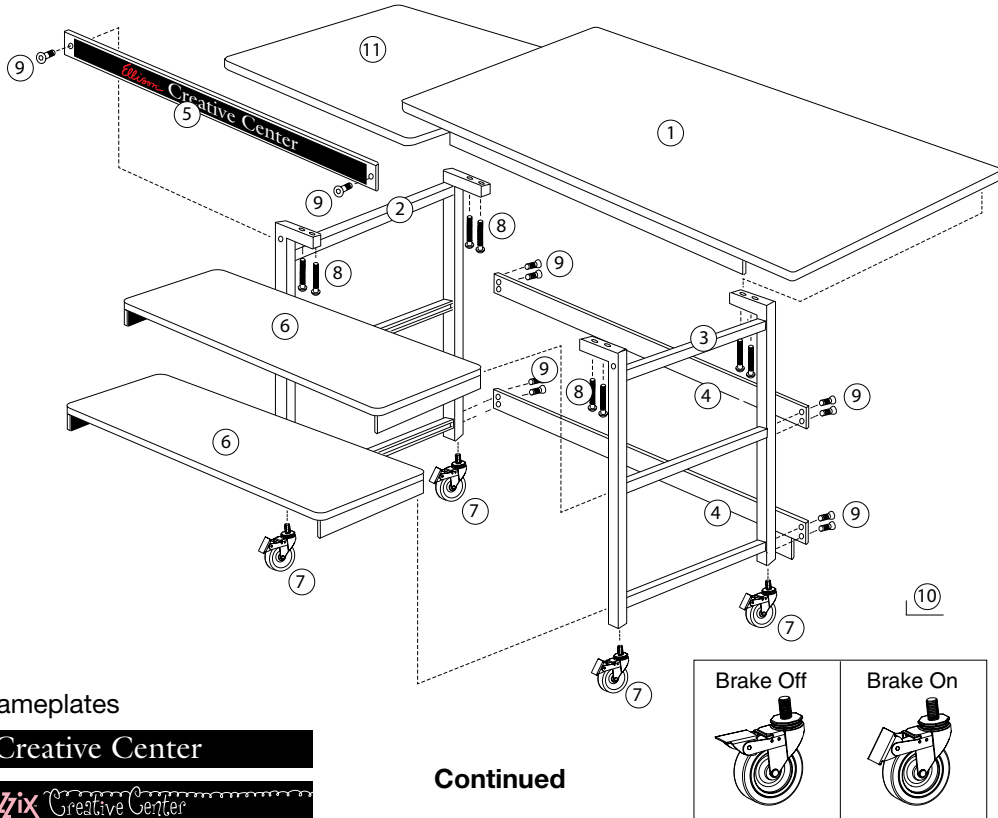

Nameplates



Continued

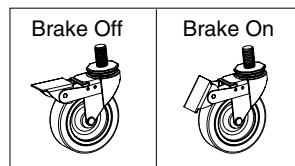



---

## Ellison®/Sizzix® Multi-Purpose Work Station

1. Place Top Assembly (Item 1) with the finished side down on a smooth, flat surface (clean cloth or staple-free cardboard).
2. Align the Left Leg Assembly (Item 2) and the Right Leg Assembly (Item 3) on their respective “L” and “R” labels on the underside of the Top Assembly. Fasten Left Leg Assembly and Right Leg Assembly with Long Screws (Item 8) using the Allen Wrench (Item 10) provided.
3. Attach one Rear Support Brace (Item 4) in the middle of the Leg Assemblies (Items 2 & 3) and one Rear Support Brace (Item 4) at the bottom of the Leg Assemblies. Use the Short Screws (Item 9) and the Allen Wrench (Item 10) provided. Do not overtighten.
4. With Castor Wheel (Item 7) brake applied (press the metal clip down), insert the screw end of the Castor into the threaded hole at the base of each Leg. Rotate clockwise, holding and using the brake clip as a wrench, until the Castor Wheel stops turning. Do not overtighten.
5. After all four Castor Wheels are secure, carefully return the Work Station to its upright position (not recommended for one person). Insert Top Sliding Shelf (Item 11) into the Top Assembly on the left side. Insert the two Middle Sliding Shelves (Item 6) into the receiving channels on the inner sides of the Leg Assemblies. Make sure the weight limit labels (Do Not Exceed 55 lbs for the Middle Sliding Shelves or 25 lbs for the Top Sliding Shelf) are in the lower right corners of the Shelves. Push the Shelves firmly until they click into their closed positions.  
**Note: NEVER pull out more than one Shelf at a time.**
6. Attach the desired Nameplate (Item 5) to the front of the Work Station with the logo facing out, using the Short Screws (Item 9) and Allen Wrench (Item 10) provided.
7. Release all four brakes on the Castor Wheels. The Ellison Multi-Purpose Work Station is ready to use.

### LIMITED WARRANTY

Ellison will repair or replace this product if, within one year of your purchase of this product, you discover a manufacturing defect and return the product to Ellison along with your written proof of purchase. All returns must be made within one year of your purchase of this product. Unless otherwise specified in writing, all such returns must be made to Ellison Educational Equipment, Inc., 25862 Commercentre Drive, Lake Forest, California 92630 USA. This warranty is expressly limited to manufacturing defects and does not include any damage or defect caused in any manner after your purchase of this product. Other than the express limited warranty set forth above, to the maximum extent permitted by applicable law, Ellison and its affiliates disclaim all express or implied warranties. NO WARRANTIES ARE MADE WITH RESPECT TO MERCHANTABILITY OR FITNESS FOR A PARTICULAR USE.

### 27211 Multi-Purpose Work Station w/Drawer